

# DISCSTAR™ H

## HORIZONTAL LENTICULAR MODULE HOUSING

The economical choice for pharmaceutical and food & beverage filtration applications for everyday use

The DISCSTAR™ H is available for 16" double open ended modules with flat gaskets (DOE). It is a highly precise stainless steel filter housing for filter modules, developed and manufactured for everyday use. The enclosed system enables depth filtration to be carried out without drip loss.

Compared to standard vertical housings the DISCSTAR™ H is turned into a horizontal position. On one side there is a closure head through which the filter modules are loaded. The closing of the device is hydraulically assisted. To ensure a proper compression of

the module stack, a center spindle can be retightened from outside. No crane is needed to open the housing. Venting valve, sight glass, pipework and instrumentation are permanently installed. Inlet and outlet are installed on the bottom side. An optional residual filter can be installed to minimize the dead volume. The horizontal design allows a much easier and complete filling of the housing.

The DISCSTAR™ H housing is much safer to operate easier to handle due to an economic chest working high and easy loading and disposing of the modules.



*DISCSTAR™ H filter housing*

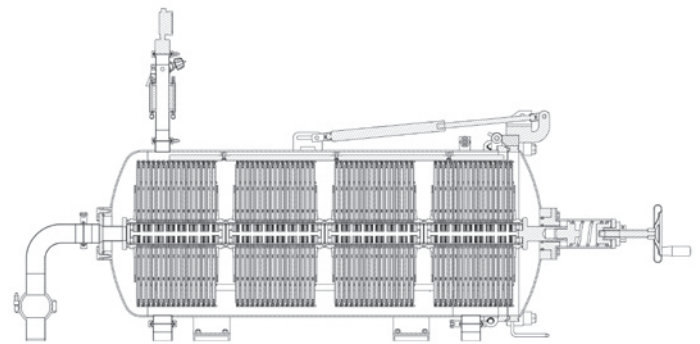

*Assembly of the modules in the housing*

### Benefits

- Easy replacement of modules / no need of crane or other lifting devices
- Easy spent module removal and transportation
- Easier to fill especially for modules with open filter media
- Saves working time because of better accessibility of modules
- Smaller footprint / reduce overall height compare to vertical design
- No product loss due to optionally integrated residual filter
- Ergonomic chest high operation
- Pipework away from the operator section
- Permanent vent valve pipework, sight glass and instrumentation
- No center post components or loose components inside the housing
- External module compression check
- Skid version with two, three or more housings available

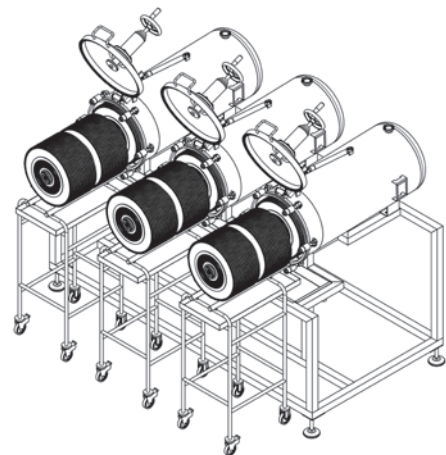

*Multi DISCSTAR™ H filter housing skid*

## Applications

### Pharmaceutical

- Decolorization with activated carbon modules
- APIs
- Enzymes
- Plant and natural extracts
- Pharmaceutical intermediates
- Active agents

### Food and Beverage

- Wine
- Tea
- Juice
- Beer
- Distilled products
- Sugars

Technical Data	
Type and size of modules:	16" with flat gasket adapter (DOE)
Number of modules:	4 (optional 3)
Max. process pressure:	-1/+6 bar liquid and gases
Max. process temperature:	-20/+140 °C
Max. filter area:	14.4 m <sup>2</sup> (with modules each 16 lenses)

Materials	
Parts in contact with product:	AISI 316L
O-Rings / Gaskets:	EPDM – FDA approved

Surface treatment	
Parts in contact with product:	Ra < 0.8 µm, mechanical polished
All other parts:	Ra < 1.6 µm, mechanical polished

Acceptance according to:	Pressure vessel guidelines PED 2014/68/EU and ATEX 2014/34/EU
--------------------------	---

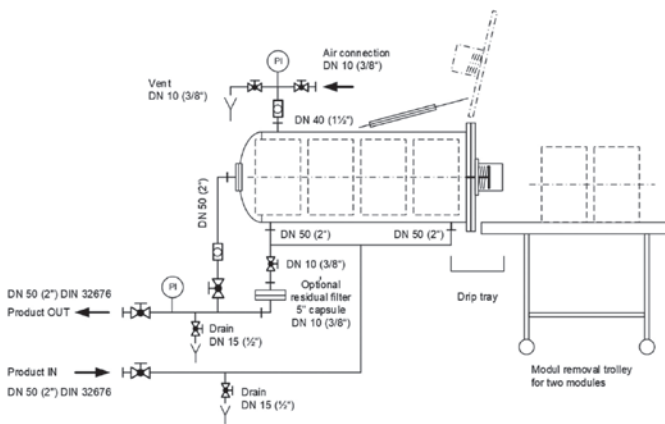

DISCSTAR™ H filter housing configuration incl. module trolley



Open DISCSTAR™ H filter housing incl. module trolley